



ROCHDALE
BOROUGH COUNCIL

Rochdale Building Control Guide

Loft Conversions & Dormers *version 3 June 2018*

Loft conversions are often seen as a simple way of obtaining additional living space, however care is needed when dealing with existing buildings.

This guide seeks to provide information on how to achieve compliance with the Building Regulations.

The solutions shown are just some examples of how to comply, other solutions and manufacturers products may achieve the requirements.

Foundations/existing structure

A trial hole should be excavated adjacent the corner of the building to verify the existing foundation is suitable to sustain the additional loads from the conversion.

The existing walls and lintels should be checked that no evidence of movement such as cracking is evident.

New floor

The existing ceiling joists are not normally suitable for use as a floor. It is common to install new floor joists to allow for the extra loads from use as living space.

Floor joists (grade C16) are sized from Eurocode 5.

47 x 145mm joists installed at 400mm centres will span up to 2.89m

47 x 170mm joists installed at 400mm centres will span up to 3.38m

47 x 195mm joists installed at 400mm centres will span up to 3.87m

72 x 145mm joists installed at 400mm centres will span up to 3.33m

72 x 170mm joists installed at 400mm centres will span up to 3.89m

72 x 195mm joists installed at 400mm centres will span up to 4.44m

An example of new floor construction is below:

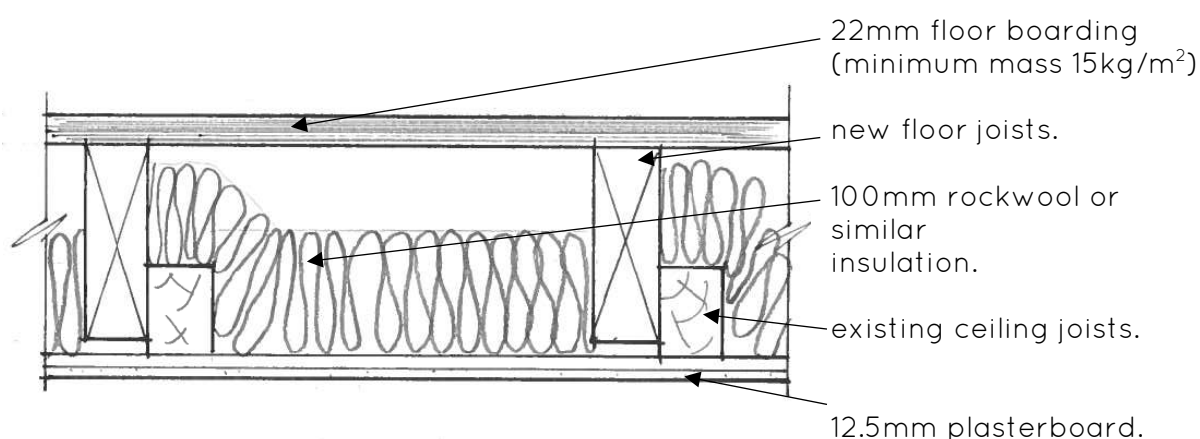

100mm Rockwool is required between joists for sound insulation.

The existing ceilings may require upgrading to provide half an hour fire resistance, if the existing is not 12.5mm plasterboard. Traditional lath and plaster ceilings will only achieve approximately 20 minutes fire resistance.

One method of upgrading is by the provision of a layer of 12.5mm plasterboard to the ceiling. Alternatively mesh can be installed in between and over joists with tightly packed rockwool between joists.

Staircase

New staircase should have maximum risers of 220mm and minimum goings (treads) of 220mm. The maximum pitch of a stair is to be 42 degrees, so for example a 220mm riser would need to have 245mm going to be under 42 degree pitch. If kite winders are to be used the minimum tread size at the newal post must be 50mm.

A continuous handrail is required set 900mm from the pitch line of the flight. Guarding should have no gaps exceeding 99mm.

The headroom to a staircase is to be 2000mm minimum, however in loft conversions a reduced standard is allowable as shown below.

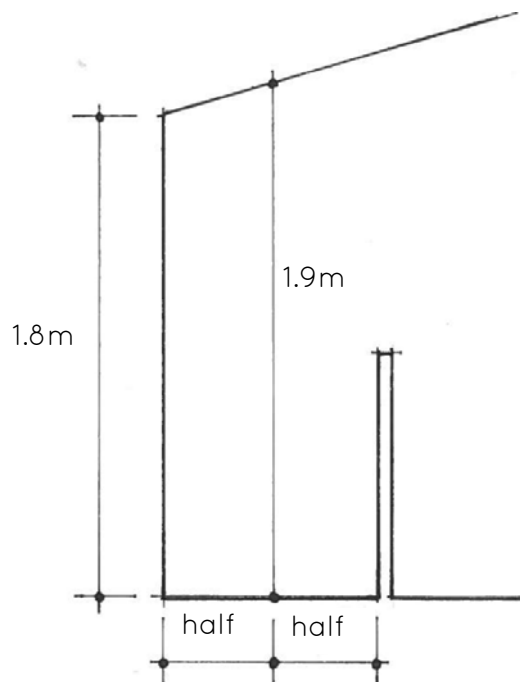

Walls: party Wall

Any gap in party walls between houses must be closed with brick/block and mortar to ensure fire separation.

It is important to note that some party walls are only 102.5mm thick and care must be taken to avoid disturbing the adjacent house. Any damage will have to be made good at your expense.

External and party walls will require upgrading to achieve the required thermal (U) value of $0.28 \text{ w/m}^2\text{K}$. The method used will depend upon the construction.

existing 215mm brickwork

25 x 47mm sw battens at 600mm centres.

62.5mm thick Kingspan K118 insulated/plasterboard

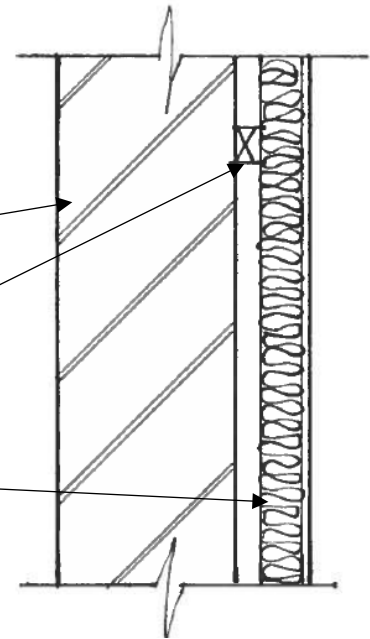

For 102.5mm brick walls 67.5mm thick Kingspan K118 insulated plasterboard is required.

Walls: stud partition

Where a partition is formed between the roof space and new bedroom the wall must achieve a U value of $0.28 \text{ w/m}^2\text{K}$. Detail below indicates how this is achieved.

Existing timber purlin.

75mm Kingspan TP10 insulation between studding.

75 x 50mm softwood studding.

32.5mm K118 insulated plasterboard to inner face of studding.

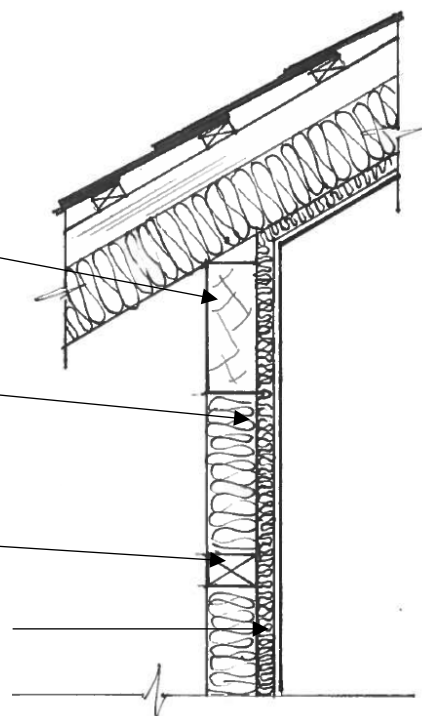

Internal partitions need to achieve half hour fire resistance sound resistance. Detail shows how this can be achieved.

75 x 50mm sw studding at 400mm centres

12.5mm plasterboard both sides.

Voids between the studding have minimum 25mm thick mineral wool (minimum density 10kg/m³).

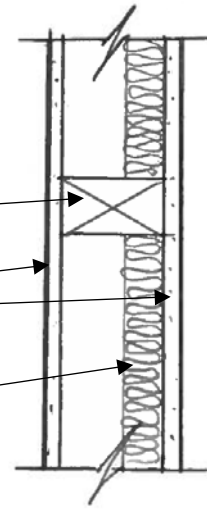

Walls: dormer

Dormer walls must achieve a U value of 0.28 w/m²K. Example dormer construction is shown below.

tiles or weatherboarding.

battens

breathable felt

19mm external quality plywood.

75mm Kingspan TP10 insulation between studding

100 x 50mm softwood studding.

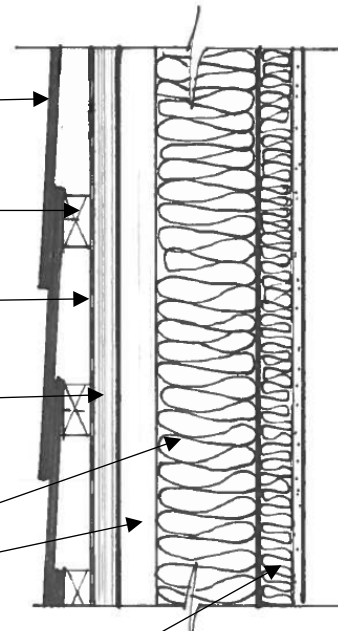

32.5mm K118 insulated plasterboard to inner face of studding. (Vapour control layer included)

The side walls of dormers are commonly supported off doubled up rafters or floor joists, the size of these will require calculation by a qualified Structural Engineer. Photo below shows rafters doubled up and bolted together.



The front walls of dormers are normally raised up off the existing inner leaf wall or a new steel beam as shown below. Steel beams and concrete padstones will require calculation by a qualified Structural Engineer.

tiles or weatherboarding on battens on breathable felt on 19mm external quality plywood

broken line indicate existing rafters cut back.

existing rafters

100 x 75 timber plate fixed to top of beam.

new steel beam

100 x 50mm softwood studding with 75mm Kingspan TP10 insulation between.

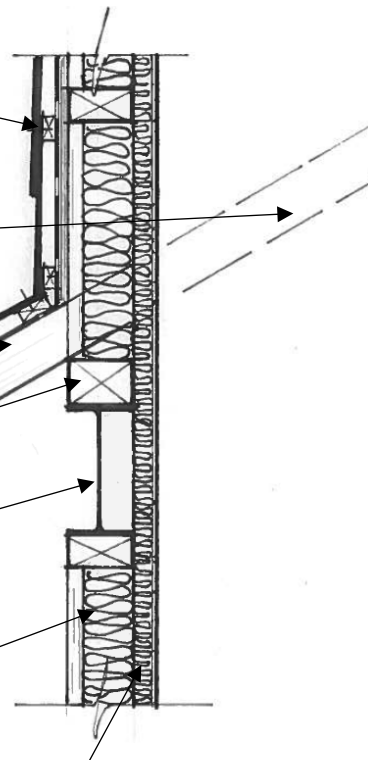

32.5mm K118 insulated plasterboard to inner face of studding. (Vapour control layer included)

100 x 100 timber posts are required at corners of dormers as shown below:

tiles or weatherboarding.

battens on breathable felt

100 x 100 corner post.

6mm Promat Masterboard for fire resistance.

19mm external quality plywood.

100 x 50mm softwood studding with 75mm Kingspan between studding.

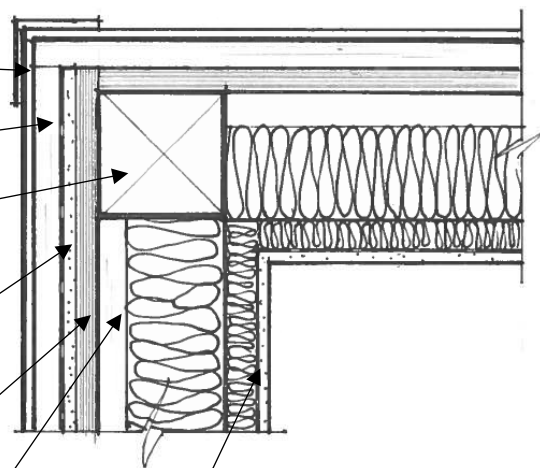

32.5mm K118 insulated plasterboard to inner face of studding. (Vapour control layer included)

Where the dormer cheeks are within 1 metre of a boundary fire resistance must be achieved from both sides this is usually done by applying Masterboard to the external face of the plywood before felt installation as shown above.

Where window openings are formed the studding should be doubled up either side and a 200 x 100mm timber lintel provided over opening. See photograph below.



Roof: structural considerations

Traditional roof construction is relatively simple to convert, however roofs formed with roof trusses need to have special attention and a structural engineer should be consulted before any roof trusses are cut to ensure the roof does not collapse.

Where a dormer is to be created a new structural beam is required at the ridge position of the roof as shown below:

Proprietary ventilated ridge.

existing rafters battened down with 100mm Kingspan between.

100 x 75 sw plate bolted to steel

32.5mm K118 insulated plasterboard.

New steel ridge beam

Flat roof joists with Kingspan between.

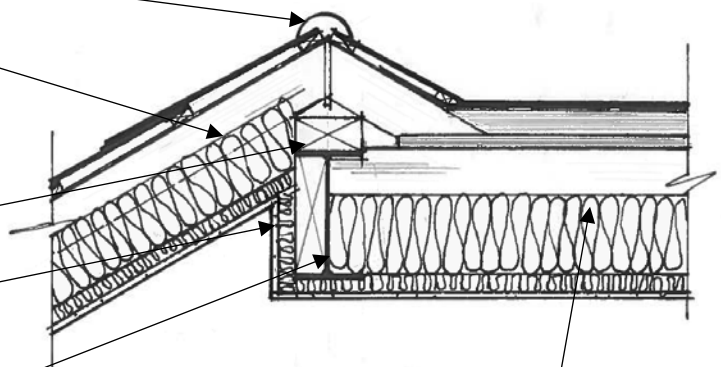

Roof: thermal upgrading of rafters

The existing roof needs to be upgraded to achieve a U value of 0.18 w/m²K. Existing rafters are often not deep enough to provide air flow and sufficient levels of insulation. It is necessary to provide battens fixed in line under existing rafters to achieve compliance. The detail below can be used.

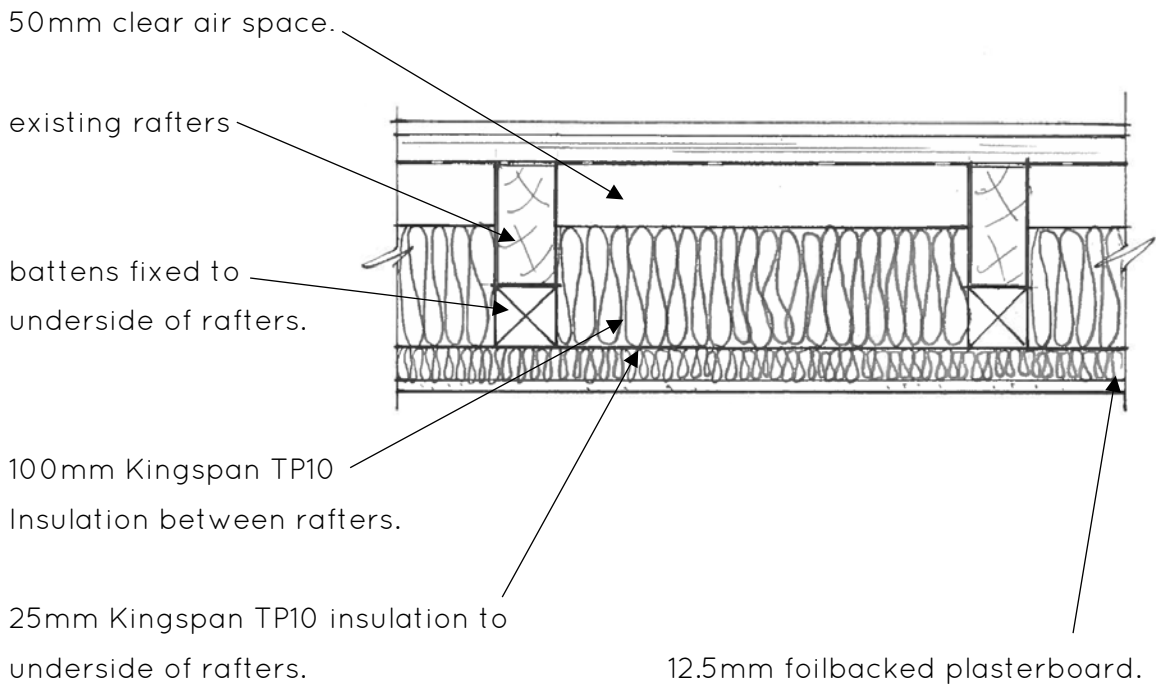

The thicker depth of insulation should always be between the rafters as if the thicker amount is placed below the rafters there is a risk of interstitial condensation which could damage the roof timbers.

If the roof is not insulated at rafter level after partition walls the insulation at the existing ceiling level will require upgrading to 270mm Knauf earthwool loft roll insulation. This is normally installed with 100mm inserted between the ceiling joists and 170mm laid at right angles over the ceiling joists.

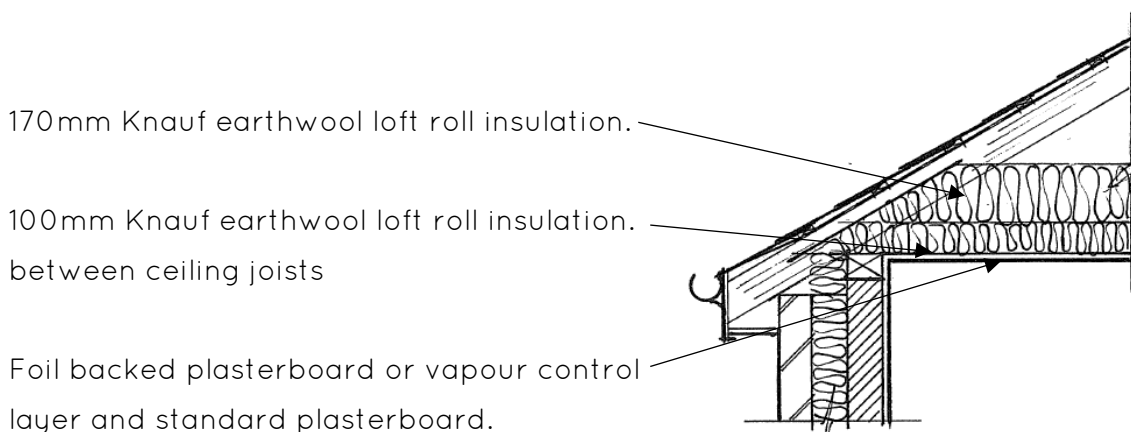

Roof: dormer construction

The type of roof over the dormer will depend on the height of the existing roof. Planning will not allow dormers to be higher than the existing house ridge. For full details please call the Planning Department on 01706 924305.

Flat roof dormers need to achieve a U value of 0.18 w/m²K. Typical flat roof construction is shown below.

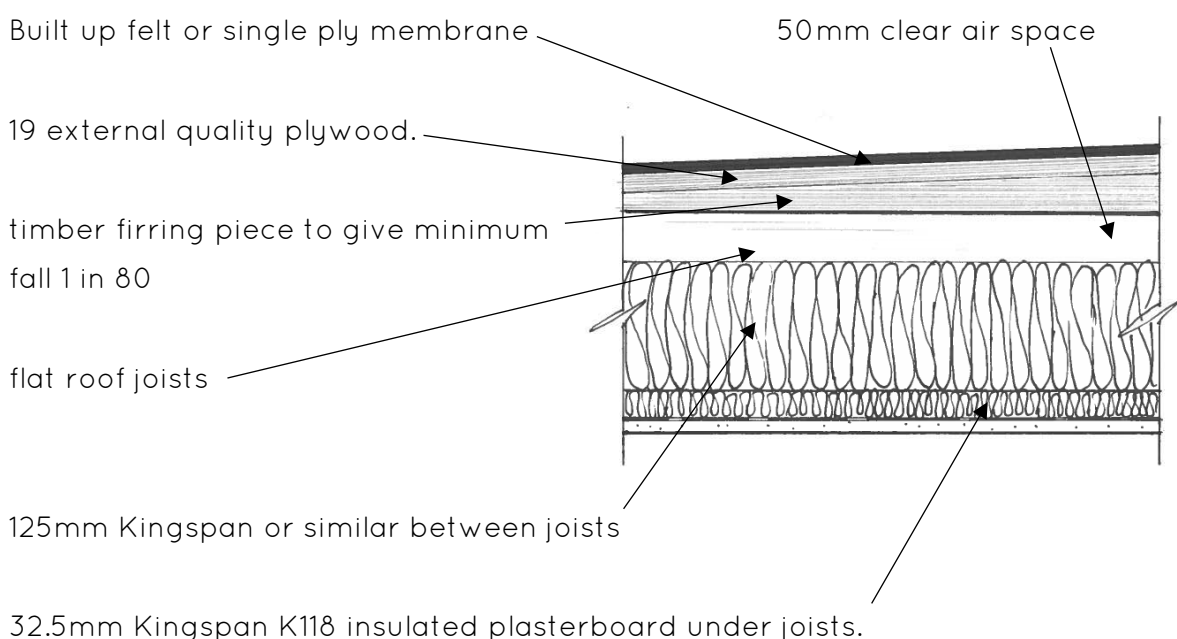

Roof: joist sizing

Flat roof joists (grade C16) are sized from Eurocode 5.

- 47 x 145mm joists installed at 400mm centres will span up to 2.84m
- 47 x 170mm joists installed at 400mm centres will span up to 3.43m
- 47 x 195mm joists installed at 400mm centres will span up to 4.02m
- 47 x 220 mm joists installed at 400mm centres will span up to 4.61m

Pitch roofs on dormers are unusual, however rafters for pitched roof (grade C16) are sized from Eurocode 5 for pitches from 15 – 22.5 degrees.

- 47 x 125mm joists installed at 400mm centres will span up to 2.4m
- 47 x 150mm joists installed at 400mm centres will span up to 3.0m
- 47 x 195mm joists installed at 400mm centres will span up to 4.08m

For a pitched roof with ceiling 270mm Knauf earthwool loft roll insulation is to be used. This is normally installed with 100mm inserted between the ceiling joists and 170mm laid at right angles over the ceiling joists.

For a pitched roof dormer the tiles used depend on the pitch which can be achieved, the list below shows some of the most common seen, for further details please refer to manufacturers details.

Roof Pitch	Roofing material
12.5	FORTICRETE Centurion REDLAND regent (15 degrees if roof includes valleys)
15	REDLAND Cambrian slate MARLEY Malvern, Wessex, Marley Mendip SANDTOFT 20/20 (plain clay appearance)
17.5	REDLAND landmark double roman, MARLEY Modern, Edgemere (slate) SANDTOFT Britlock (slate)
22.5	FORTICRETE Gemini (plain clay equivalent) MARLEY Birkdale, Rivendale, Garsdale,
30	Natural Slate- refer to BS 5534:2003
35	Plain Clay Tiles (Rosemary's)

Roof: ventilation

As the roof is to be insulated there is a risk of interstitial condensation therefore ventilation is required at eaves and the

Eaves level ventilation equivalent in free area to a 25mm slot running the whole length of the eaves. This can be achieved using proprietary vents.

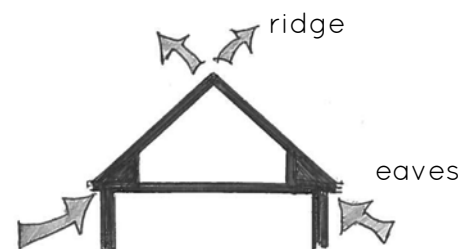

High level ridge ventilation should be equivalent in area to a 5mm slot for the length of the ridge. Proprietary ventilated dry ridge tiles can be used to achieve this.

Windows

Roof lights should be installed to the manufacturer's instructions and not less than 15 degree roof pitch. The rafters need to be doubled up around the roof light for stability.

New windows are to achieve a minimum WER (window energy rating) band C, or a U value of 1.6 W/m²K. Trickle ventilators are required in windows to provide 2,500mm² equivalent area in wet rooms and 5,000mm² equivalent area in all other rooms. The size of vents is usually printed on the edge. Roof lights have a built in trickle function.

Fire precautions: single storey bungalows

The conversion of a loft in an existing single storey bungalow will not need a protected escape route as long as all the new first floor bedrooms have windows which are suitable for means of escape. Velux and other manufacturers make windows which are suitable for means of escape.

Escape windows must have a minimum size in either direction of 450mm. A clear opening area of 0.33 m² is required for escape which equates to an opening size of 450mm x 750mm.

The height to the bottom of the actual opening should be between 800mm and 1100mm measured from the floor level, as shown below.

The sketch indicates how the dimension is measured.

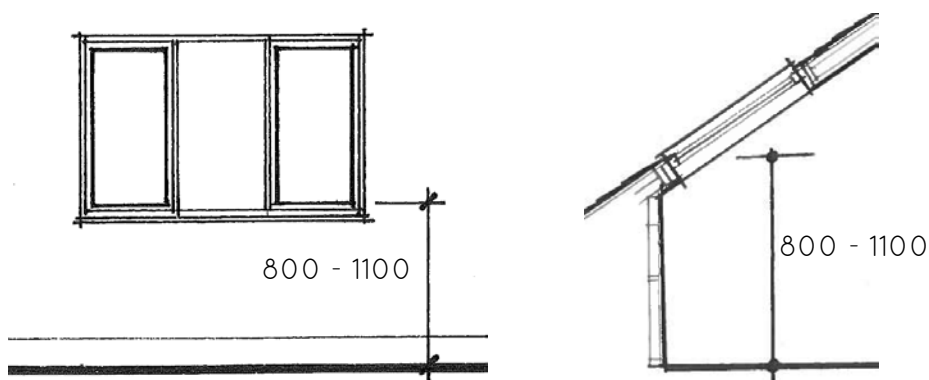

Fire precautions: 2 storey house

The conversion of a loft (with or without dormers) in an existing 2 storey house will need a protected escape route to be formed leading to a final exit (front door) as the example shown below.



Ground Floor Plan

First Floor Plan

Second floor plan

- Indicates smoke detectors.
- * Indicates fire doors and frames.

Alternatively a protected route with two escape routes at ground floor level can be used (typical in old terrace houses), as the example below.



Ground Floor Plan

First Floor Plan

Second floor plan

All walls and floors to the protected route are to achieve half an hour fire resistance. This may involve over-boarding walls and ceilings in plasterboard.

A protected route requires all the doors and frames off the route to be fire resistant. A minimum FD20 is required. Intumescent strips are to be installed in the frame or door. These expand if exposed to fire to prevent fire spreading into protected route to help people escape. Intumescent strip pictured below.

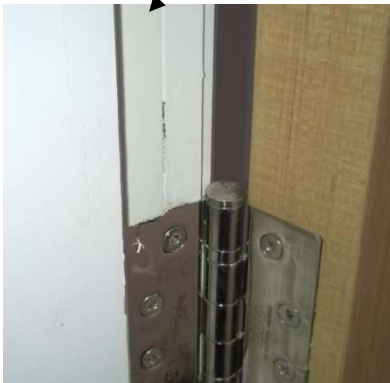

Smoke strips should not be used as they will stop the smoke alarms activating giving you early warning. Self-closing devices are not required to fire doors.

Any glass in doors/frames to the protected route must be half hour fire resistant.

Fire precautions: smoke detection

Mains wired smoke alarms are required in the circulation space used to access new room these must conform to BS5446-2:2003 or BS EN 14604:2005 and be installed by a registered electrician. See plan above.

Electrical work

Electrical work must be undertaken by a competent person who has sufficient knowledge to undertake the work. Electrical work must conform to the 17th edition of the IEE wiring regulations. The most suitable way of achieving compliance is to employ a competent person registered with NICEIC, NAPIT, ECA or ELECSA.

Lighting & heating

75%(3 per 4) of new light fittings should be low energy light fittings with lamps having a luminous efficacy greater than 45 lamp lumens per circuit-watt and a total output greater than 400 lamp lumens.

New heating extended off the existing system should be provided with Thermostatic valves to control the temperature.

Planning Permission

This is a separate matter from Building Regulations.

Roof lights are allowed in the front, side and rear roof slopes without Planning Permission unless the property is a Listed Building, in a Conservation Area or has no Permitted Development rights.

Dormers are allowed in the side and rear roof slopes of houses under Permitted Development rights subject to certain conditions, however front dormers would require Planning Permission and are only allowable in very specific circumstances. For further information regarding planning permission please check the [Planning Portal](#) or call 01706 924305.

Inspections

We normally undertake inspections before any work is covered up, ideally at the following stages on loft conversions and dormers:

Foundations - trial hole to check existing foundations.

Pre-plaster - to view all structural and insulation elements before plasterboard applied.

Drainage - to view new external drain connections below ground.

Completion - when the work is complete and electrical certification is available.

For inspections call our office on 01706 92437. Please note inspections take place in the morning between 8:30 and 12 noon.

Bibliography/Further Guidance

BSI, 2002, *BS 5250: 2011 Code of practice for the control of condensation in buildings*, British Standards Institution, London.

NBS, 2013, *Building Regulations 2010 Approved Document B Fire safety Volume 1 - Dwellinghouses*, HM Government, London,
<www.planningportal.gov.uk>

NBS, 2013, *Building Regulations 2010 Approved Document K Protection from falling, collision and impact*, HM Government, London,
<www.planningportal.gov.uk>

NBS, 2010, *Building Regulations 2010 Approved Document L1B Conservation of fuel and power in existing dwellings*, HM Government, London,
<www.planningportal.gov.uk>

DCLG, 2010, *Building Regulations 2000 Approved Document F Ventilation*, Department for Communities and Local Government, London,
<www.planningportal.gov.uk>

RMBC, 2014, *Building Control Guide to Approved Document L1B*, Rochdale Building Control, Rochdale, <www.rochdale.gov.uk/buildingcontrol>

RMBC, 2014, *Building Control Guide to Approved document F*, Rochdale Building Control, Rochdale, <www.rochdale.gov.uk/buildingcontrol>

RMBC, 2014, *Building Control Guide to Escape Windows*, Rochdale Building Control, Rochdale, <www.rochdale.gov.uk/buildingcontrol>

RMBC, 2014, *Building Control Guide to Approved Document C*, Rochdale Building Control, Rochdale, <www.rochdale.gov.uk/buildingcontrol>

01706 924327

building.control@rochdale.gov.uk

Building Control Services
Rochdale Borough Council
Economy Directorate
Number One Riverside
Smith Street
Rochdale
OL16 1XU

RBC.LC.V3.AT.040618



ROCHDALE
BOROUGH COUNCIL